

Membrane-based on-line optical analysis system for rapid detection of bacteria and spores

Pierre N. Floriano^a, Nick Christodoulides^a, Dwight Romanovicz^a, Bruce Bernard^a,
Glennon W. Simmons^a, Myles Cavell^a, John T. McDevitt^{a,b,c,*}

^a Department of Chemistry and Biochemistry, The University of Texas at Austin, Austin, TX 78712, USA

^b Center for Nano and Molecular Science and Technology, The University of Texas at Austin, Austin, TX 78712, USA

^c Texas Materials Institute, The University of Texas at Austin, Austin, TX 78712, USA

Received 4 June 2004; received in revised form 6 August 2004; accepted 24 August 2004

Abstract

We report here the adaptation of our electronic microchip technology towards the development of a new method for detecting and enumerating bacterial cells and spores. This new approach is based on the immuno-localization of bacterial spores captured on a membrane filter microchip placed within a flow cell. A combination of microfluidic, optical, and software components enables the integration of staining of the bacterial species with fully automated assays. The quantitation of the analyte signal is achieved through the measurement of a collective response or alternatively through the identification and counting of individual spores and particles. This new instrument displays outstanding analytical characteristics, and presents a limit of detection of ~500 spores when tested with *Bacillus globigii* (*Bg*), a commonly used simulant for *Bacillus anthracis* (*Ba*), with a total analysis time of only 5 min. Additionally, the system performed well when tested with real postal dust samples spiked with *Bg* in the presence of other common contaminants. This new approach is highly customizable towards a large number of relevant toxic chemicals, environmental factors, and analytes of relevance to clinical chemistry applications.

© 2004 Elsevier B.V. All rights reserved.

Keywords: Bacteria; *B. globigii*; Microchip; Epifluorescence; Immunoassay; *B. anthracis*

1. Introduction

Prompt detection and identification of potentially harmful bacteria is essential in the medical, environmental, and food industries. Recent events have emphasized the need for appropriate techniques to detect such micro-organisms when used in acts of bioterrorism. As bacteria require very little to grow, a great number of them can easily be manufactured for use as biological warfare agents. *Bacillus anthracis* (*Ba*), or anthrax, initially a threat to humans only through infected herbivores, has become such an agent. As evidenced by the anthrax attacks of October 2001 on US soil and the extensive list of potential biological warfare agents (CDCA), there is an urgent need for a detection system capable of detecting

very low numbers of spores, with great selectivity, and in a timely fashion. Strategic locations for the detection of spores and bacteria include all mail-sorting facilities (Dull et al., 2002). For this particular application, continuous monitoring of the mailroom atmosphere is crucial in order to detect small amounts of contaminants while they are still contained within the facilities. As the postal office environment contains extreme amounts of paper and textile fiber, dust, and fluorescent brighteners, it represents a very complex matrix in which the detection of small quantities of spores is rendered very complicated.

Traditional methods of detection require the growth of single bacteria into bacterial colonies in different types of media, followed by a lengthy identification process involving morphological and biochemical tests (Francis et al., 2001; Paton and Jones, 1975; Kaprelyants and Kell, 1992; Phillips et al., 1983, 1985; Davey et al., 1999; Davey and Kell, 1997;

* Corresponding author. Tel.: +1 512 471 0046; fax: +1 512 232 7052.
E-mail address: mcdevitt@mail.utexas.edu (J.T. McDevitt).

Mason et al., 1995). These procedures, although often providing very accurate results, suffer from poor specificity, and repose on the expertise of highly trained personnel. Additionally, they often require complicated interpretation with complete analysis time typically approaching 72 h, which makes them unsuitable for online rapid analysis. Recent efforts have been directed towards developing approaches suitable for the entrapment or capture of bacteria, based on a combination of physical characteristics of the capturing medium and the affinity of the bacteria for a variety of chemical functionalities (Lee et al., 1997; Szczesna-Antczak and Galas, 2001; Chapman et al., 2001). While rapid, these methods are non-specific, requiring completion of multi-step analysis for identification and quantification.

Most commonly available assays for the detection of spores or bacteria involve the use of enzyme-linked immunosorbent assays (ELISA) (Morais et al., 1997). While demonstrating high specificity, reproducibility, and capacity for multiplexing through the use of specific antibodies, these methods generally require lengthy analysis times, and are not compatible with real-time analysis. A large amount of efforts has been made recently to decrease analysis time and improve sensitivity and selectivity through the application, modification, or combination of various techniques. These include polymerase chain reaction (PCR) (Wu et al., 2002; Makino et al., 2001; Radosevich et al., 2002; Wilson et al., 2002; Iqbal et al., 2000; Belgrader et al., 1999, 2001; Cheun et al., 2001), electrochemical transduction (Dill et al., 2001, 1997; Yu, 1996, 1998; Brewster et al., 1996; Brewster and Mazenko, 1998; Mazenko et al., 1999; Gau et al., 2001), optical and microarray detection (Cheng et al., 1999; Chuang et al., 2001; Song et al., 2002; Rowe et al., 1999; King et al., 2000), flow-through immunofiltration (Morais et al., 1997; Abdel-Hamid et al., 1999a,b; Weimer et al., 2001), acoustic sensors (Ivnitski et al., 1999), capillary electrophoresis (Shintani et al., 2002), flow cytometry (Davey et al., 1999), and oligonucleotide probes and hybridization detection schemes (Steinert et al., 2002; MacGregor et al., 2001; Bockelmann et al., 2002; Gau et al., 2001; Yang et al., 2002; Liu et al., 2001) However, general sensor strategies rarely feature together the highly desired long list of attributes necessary for the creation of an “ideal sensor”, as is demonstrated by the small number of commercially available sensing units (Ivnitski et al., 1999).

Methods based on PCR analysis have been chosen by the US Postal Service (USPS) as a preliminary technological response to an urgent need for a rapid detection method for *B. anthracis*. Despite the excellent specificity, sensitivity, and recent outstanding advances of this technology (McBride et al., 2003; Belgrader et al., 2003), some of the drawbacks include difficult sample preparation, long analysis time, the need for trained personnel, high reagent costs, potential contamination, false positives, and poor adaptability to multiplexing. In a similar manner to the Joint Biological Point Detection System (JBPDS) (NATIBO, 2001), which was designed to detect a biological agent within a minute upon release and identify the species in less than 15 min, our goal is to design

and build a system that would use a two-step approach for the detection and identification of bacteria and spores. For document-handling applications, as required by USPS, it is desirable to develop rapid tests that can be used in conjunction with PCR confirmation tests to create a practical and cost-effective methodology suitable for the identification of bioterrorist threats (Fox et al., 2002). Further, the availability of such a rapid and specific spore and bacteria detection system would have a profound impact on food/water safety and important humanitarian efforts.

We have recently reported the use of a bead-based microchip technology (Lavigne et al., 1998; Goodey et al., 2001; Curey et al., 2001) to measure pH, detect metal cations, enzymes, proteins, DNA, and to assess cardiac risk through the monitoring of C-reactive protein in human serum (Christodoulides et al., 2002). These microchip-based applications repose on the use of polymer microspheres placed in the micro-etched wells of a silicon chip. By applying a mechanical entrapment strategy and the standard optical methodology of our system, we demonstrate here an efficient visualization of bacteria and spores. This novel approach is exploited and demonstrated here in the context of online detection of bacillus spores in mail-handling facilities.

2. Experimental

2.1. Flow cell

The flow cell assembly was created from a three-piece stainless steel cell holder consisting of a base, a support and a screw-on cap. Two circular polymethylmethacrylate (PMMA) inserts house the Nuclepore® (Millipore, USA) membrane. These two PMMA inserts have been drilled along their edge and one side to allow for passage of the fluid to and from the chip through stainless steel tubing (#304-H-19.5, Microgroup, Medway, MA). The tubing, which was fixed with epoxy glue in the drilled PMMA inserts, had an outer diameter of 0.039" (19.5 gauge), and a 0.0255–0.0285" inner-diameter. The bottom PMMA insert is modified in order to feature a drain and to contain a plastic screen disc (Pall Corporation, New York) that acts as a support for the filter. The top insert also features an additional outlet, which is used for regeneration of the filter. Silicone tubing is fitted on the stainless steel tubing, and as such is readily compatible with a wide range of fluidic accessories (i.e. pumps, valves, etc.) and solvents. The flow cell was shown to be resistant to leaks and pressures generated by flow rates as high as 20 mL/min.

2.2. Fluid delivery, optical instrumentation and software

The complete analysis system consists of a fluidics system composed of four P625/275 Instech peristaltic pumps (Instech, Plymouth, PA), dedicated to the delivery of the analyte,

antibody, wash buffer, and clean-up of the flow cell in a regeneration mode. Its integrated software was used to assure fluid delivery to the chip, and to accommodate wash cycles through the proper use of Series 075-P2 pinch valves (Bio-Chem Valve, Boonton, NJ) and pumps. Nuclepore® track-etched membranes of 5 and 0.4 μm pore size were also used as pre-filters. This fluidics system is coupled to a flow cell positioned on the motorized stage of a modified compound BX2 Olympus microscope. The microscope is equipped with various objectives, optical filters, and a charged-coupled device (CCD) camera, the operation of which can be automated.

A mercury lamp was used as the light source. Fluorescence images shown in this report were produced with a fluoroisothiocyanate (FITC) filter cube (480 nm excitation, 505 long pass beam splitter dichroic mirror, and 535 nm \pm 25 nm emission), and captured by a DVC 1312C (Digital Video Company, Austin, TX) charge-coupled device mounted on the microscope and interfaced to Image Pro Plus 4.0 software (Media Cybernetics). Counting macros were written for both the Image Pro Plus and Image J (Bethesda, MD, USA) environments. Areas of interest in the images were selected in an automated fashion and used to extract numerical values of the red, green, and blue (RGB) pixel intensities, and spore counts. As the antibody fluorescent label emits at 519 nm, only the green values were analyzed. Control and automation of fluidic and optical systems was realized with a Pentium III Dell Precision 420.

2.3. Reagents

Phosphate buffer saline (PBS), pH 7.4 (Pierce, #28374; 0.008 M Na_3PO_4 , 0.14 M NaCl, 0.01 M KCl) was filtered through a 0.2 μm pore size syringe filter (Whatman 25 mm, 0.2 μm polyethersulfone (PES) filters #6896–2502). Polyoxyethylene–sorbitan monolaurate (Tween-20) and bovine serum albumin (BSA) were purchased from Sigma (#P-1379, and #A-0281). The anti-*Bacillus globigii* (*Bg*) antibody, generously donated by Tetracore Inc. (Gaithersburg, MD), was tagged with a fluorophore according to the protocol described in the Alexa Fluor® 488 Protein labeling kit from Molecular Probes (#A-10235), and stored at 4 °C until use. The final concentration of the labeled anti-*B. globigii* was 0.5 mg/mL. When prepared for the assay the antibody was diluted 1:50 in a filtered (0.2 μm) solution of 1% BSA/PBS. The spore preparations were provided by Edgewood/Dugway Proving Grounds. Spores were plated onto Petri dishes with *Luria Bertani* (*LB*) medium, composed of Bacto Tryptone, Bacto Yeast Extract, and Agar Technical, purchased from Difco (#211705, #212750, #281230, respectively). Distilled water, de-ionized with a Barnstead nanopure column was sterilized by autoclaving for 30 min at 121 °C.

2.4. Polymer microsphere solutions

Green fluorescent 1 and 2.3 μm polymer microspheres were purchased from Duke Scientific Corporation (Palo Alto,

CA, USA). A bright line counting chamber, or hemacytometer (Hausser Scientific, Horsham, PA) was used to determine the exact concentration of bead solutions (Berkson et al., 1939).

2.5. *Bg* spore preparation and characterization

A 1 mg/mL spore stock solution (A) was prepared in sterile water. The concentration of spores per mg of preparation was evaluated by growing colonies on LB culture medium and expressed in colonies formation unit (CFU) per milligram of spore. The average concentration was determined to be 3×10^8 CFU/mg of spore preparation.

2.6. Assay optimization

The specificity of the tetracore antibody for *Bg* spores was first confirmed with in-tube reactions that were subsequently evaluated with fluorescence microscopy of stained spores on glass slides. The antibody was then employed for the detection of *Bg* spores captured on the filter membrane of our system. Parameters evaluated to obtain the highest signal to noise ratio for this on-line assay included: (a) the effect of pre-treating the system's tubing and filter membrane with BSA (i.e. blocking of non-specific binding sites for the detecting antibody); (b) varying the rate (i.e. flow rate) of antibody introduction to the flow cell; (c) varying the antibody concentration; (d) varying the incubation time of the antibody with *Bg* spores; (e) identifying the optimal exposure time for image capture; and (f) comparison of uni-directional mode of antibody flow to the cell versus re-circulation.

2.7. Dose response curve

To establish the standard curve, spore solutions were prepared in a similar fashion as described previously with PBS instead of sterile water to cover the range from 1 ng/mL to 1 mg/mL. For each solution, an assay was conducted through execution of the following steps. The solution is introduced through pump 1 for 60 s at a flow rate of 1 mL/min, and followed by a 60 s PBS wash through pump 2 with the same flow rate. The antibody is then passed to the flow cell through pump 3 for 300 s (0.3 mL/min). A final 90 s wash ensures the removal of any unbound or non-specifically attached antibody. The background signal was evaluated through five independent measurements of the signal obtained from the passage of antibody in five different spore-free flow cells. A fluorescent micrograph of the signal remaining after the final wash was recorded from five randomly selected areas of the flow cell and the signal was expressed both as the density of green intensity per pixel and individual spore counts. Graphs representing the average green density per pixel as a function of spore concentration, and spore count as a function of

spore concentration, were constructed. For both plots, linear regression curves were calculated.

2.8. Electron microscopy

Correlative light and electron microscopy was accomplished by placing a 5 μL aliquot of antibody-stained spores on a Formvar-coated TEM grid (Maxtaform H2 finder grids, Ted Pella Inc). Due to the thick walls of the spores, it was possible to avoid more complex dehydration regimens and simply allow the spore suspension to air dry. After a suitable area was located and photographed with fluorescence microscopy, the grid was placed in a Philips 420 TEM and the same grid square was photographed. The grid was then affixed to an aluminum stub with carbon tape and sputter-coated with gold palladium. Using a Leo 1530 scanning electron microscopy (SEM), images were captured from the area of interest.

3. Results and discussion

3.1. Description of the system

Our traditional flow cell assembly (Lavigne et al., 1998; Goodey et al., 2001; Currey et al., 2001; Christodoulides et al., 2002) (Fig. 1) was modified in order to accommodate the capture of bacterial species using a filter membrane placed within the device. Briefly, two circular polymethylmethacrylate inserts (A) housing a nuclepore track-etched membrane are held in a three-piece stainless steel cell holder consisting of a base, a support and a screw-on cap. An exploded view of the flow cell is provided in Fig. 1B. Each insert features a length of stainless steel tubing, which enters a hole in the side of the PMMA disk. The top insert also features an additional

outlet which is used for regeneration of the filter. We investigated various types of filter membranes (SEM micrograph of the filter shown in Fig. 1C), and as was suggested by previous independent studies (Mazenko et al., 1999; Brewster and Mazenko, 1998) Nuclepore[®] track-etched membranes were chosen over nitrocellulose, nylon, and cellulose acetate because of their better resistance to non-specific binding of the antibody and other stains, and their inertness to a variety of reagents and buffers. These membranes feature very reproducible sub-micron-size pores that are fairly evenly distributed, allowing for good flow dynamics through the filter. Additionally, the flow cell assembly keeps the membrane sufficiently flat to enable the capture and detection of all spores on a single focal plane through epifluorescence microscopy.

The complete analysis system is shown in schematic in Fig. 2. The sample input line (i), can be interfaced to the end-line of an aerosol system, or directly to a vial containing a transferred sample. Reagent containers r_1 , r_2 , and r_3 (ii) contain respectively PBS, the antibody solution, and PBS for regeneration of the filter. Peristaltic pumps p_1 , p_2 , p_3 , and p_4 (iii) are dedicated to the delivery to the flow cell of the analyte, PBS, the antibody solution, and PBS for regeneration. The sample, antibody, PBS, and regeneration lines are also filtered with pre-filters f_1 , f_2 , f_3 , and f_4 (iv) to screen out large particulate matter. Pre-filter f_1 is a Nuclepore[®] filter with a pore size of 5 μm . Pre-filters f_2 , f_3 , f_4 are 0.4 μm Nuclepore[®] filters. The nature and pore size of each filter was optimized in order to satisfy efficient capture of large dust particles or particulate matter aggregates, while resisting clogging and letting the analyte of interest pass through. Spores, whose size is smaller than the pores of pre-filter f_1 , are passed through a fluidics manifold (v), and captured in the analysis flow cell (vi), through the use of valves v_1 , v_2 , and v_3 (vii, viii, and ix). Details of the light source and microscope optical assembly (x), the charge-coupled device (xi), fluidics

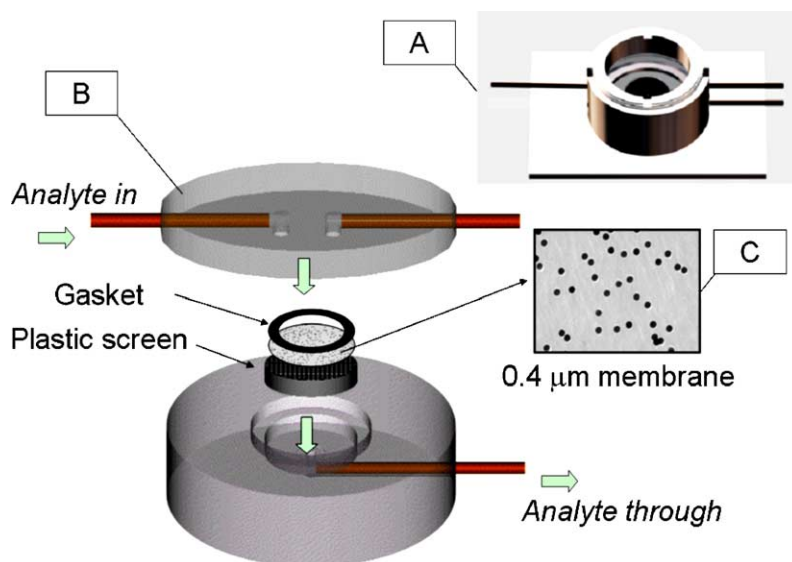

Fig. 1. Description of the membrane-based flow cell capture system.

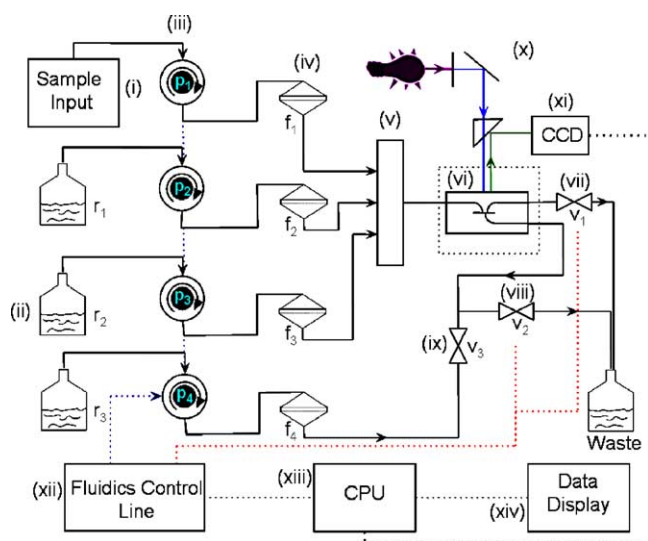

Fig. 2. Schematic drawing showing the total analysis system.

control line (xii), computer (xiii), and monitor (xiv), are given in Section 2.

3.2. Bead tests and functionality

In order to demonstrate the functionality as well as the analytical validity of our system, we challenged our integrated system with 2.3 and 1 μm fluorescent polymer microspheres. The size of these particles was chosen to best simulate populations of spores and bacteria. Increasing numbers of 2.3 μm beads captured on the membrane were imaged at various magnifications (Figure S1, Supplementary Materials). Calibration curves displaying the average density of green per pixel as a function of added volume of bead suspension were calculated from the analysis of the pictures shown in Figure S1, and are provided in supplemental materials (Figure S2). Examination of these graphs reveals that the linearity of the detected response is not affected by the magnification. However, as expected, the slope of the regression lines increases with the magnification, as the signal from the beads is brighter at higher magnifications. Since the magnification does not change the linearity of the calibration curves, and in order to accommodate a sustained flow through the flow cell, an objective of five times was chosen for the assay.

3.3. Spores and bacteria

To further illustrate the capabilities of our detection system, we targeted *B. globigii*, a commonly used non-pathogenic simulant for *B. anthracis*. An immuno-assay was established where *Bg* spores were captured on the membrane and then stained with a fluorescently labeled Alexa[®] 488-labeled anti-*B. globigii* specific antibody. Our studies revealed that blocking the system's tubing and the flow cell's filter chamber with BSA offered no significant advantage

for the assay in terms of reducing the non-specific signal. Nonetheless, we found that when 1% BSA was included in the antibody solution, the *Bg*-specific signal was enhanced, resulting in a higher signal to noise ratio and, therefore, a more sensitive assay. The optimal conditions for the assay were an incubation time of 5 min with 1.5 mL of *Bg*-specific antibody at 10 $\mu\text{g}/\text{mL}$, followed by the introduction of the antibody in the flow cell in a uni-directional mode (i.e. in to flow cell and out to waste), at a flow rate of 0.3 mL/min.

The studies also showed that re-circulation of the antibody did not offer any significant advantage in terms of shortening the assay time or decreasing its detection limit. Even though re-circulation could potentially reduce the amount of antibody utilized in the assay, we decided to move away from such an approach due to problematic precipitation of the antibody reagents. Likewise, precipitated antibody could be captured by the membrane and thus result in an increase of the non-specific signal. On the contrary, there was very little precipitation of the detecting antibody when delivered in uni-directional mode. As shown in Fig. 2, we equipped the system with a 0.4 μm pre-filter (f_3), which prevented any precipitated antibody from reaching the analysis flow cell, and resulted in a much cleaner assay. Finally, we determined that the exposure time providing the highest signal to noise ratio for capturing the final images for this assay was 184 ms. This exposure time was such that it produced the strongest *Bg*-specific signal and the weakest background, non-specific signal resulting from contaminants such as dust, irrelevant unstained bacteria and fluorescent paper fibers, all of which could potentially be found in the system.

In order to demonstrate the specificity of the interaction of the anti-*B. globigii* antibody with the *Bg* spores, we conducted correlation studies between the fluorescence micrographs (Fig. 3A), and the images obtained from scanning electron microscopy (Fig. 3B). The Formvar-coated TEM finder grid made it possible to unequivocally locate the same area in each instrument, clearly indicating that the fluorescence signal arises from the Alexa[®] 488-tagged antibody that is specifically binding to the *Bg* spores. Zooms of both regions on four individual spores are shown respectively in Fig. 3C and D. Digital superimposition of these two regions further points at the excellent specificity of the new method (Fig. 3E). Fluorescence micrographs obtained at a total magnification of $\approx 400\times$ are shown in order to better represent this correlation. However, the correlation of the fluorescence signal from spores with TEM or SEM micrographs is also established with magnification as low as $\approx 100\times$.

The limit of detection of our system was determined through a dose-dependence study. Aliquots of the spore solutions were plated to determine the exact spore concentration in terms of colony forming units per milliliter. An assay was run for each aliquot with concentration ranging from 30 to 30,000 CFU/mL. The signal for each concentration of

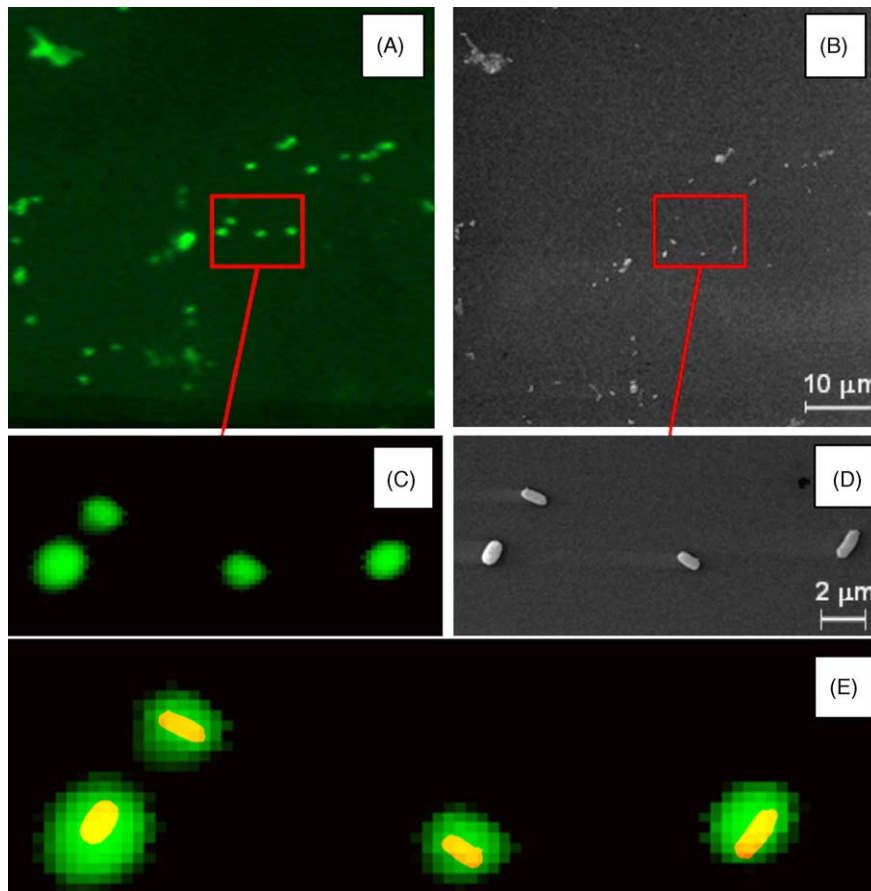

Fig. 3. Correlative light and electron microscopy.

spores was measured as both the average density of green of the entire image, and the total number of identified spores. The background was determined as the signal obtained after passage of the antibody alone through a blank filter and subsequent rinsing with PBS. Standard deviations were calculated from the average of five such measurements of the background or blanks. The limit of detection (LOD) for both approaches was calculated using the regression equation whereby the intersection between the data line and the level defined by 3 standard deviations above the average background noise. The LOD was established to be ~ 1100 spores from the calibration curve shown in Fig. 4A, using the integrated average density of green as the signal. Counting algorithms were developed within standard imaging applications in order to evaluate the signal as the total number of individual spore counts. These counts were available through an automated custom macro using various algorithms designed to remove the background, recognize shape and size of the analyte of interest, and adjust for the potential presence of clusters. Results, as shown in Fig. 4B, show a decreased limit of detection of ~ 500 spores using this method, the difference being explained by increased background discrimination with the individual enumeration. The possibility of using both individual counts and integrated signal is extremely important as this significantly extends

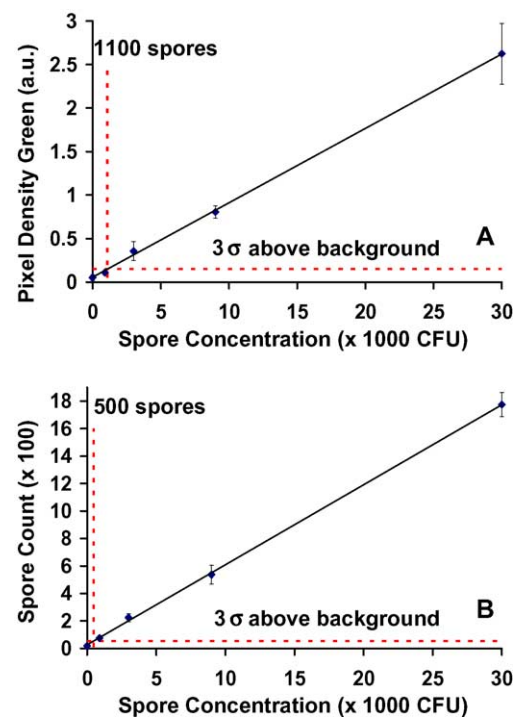

Fig. 4. Dose–response curve obtained for increasing spore amounts with the signal expressed as average fluorescence intensity in the green channel (A), and as the total of individual spore counts (B).

the dynamic range of this instrument. Indeed, for higher spore concentrations (not shown here), where the number of overlaps between adjacent spores is too overwhelming for individual counts to be performed, the integrated signal was found to be a more accurate estimate of the actual spore concentration.

While the excellent limit of detection here provided for a rapid spore assay may be attributed in part to the choice of the antibody used in this study, a number of prior studies completed with our membrane system on other cellular assays yield similarly impressive analytical characteristics. Direct comparisons of the LOD values for bacillus spore with the gold standard method of ELISA are insightful into the general capabilities of the new system, but must be viewed with some caution as the choice of reagents influences the LOD values. Typical ELISA detection limits for the same system fall into the range of 10^4 – 10^6 spores (Speight et al., 1997; Rowe et al., 1999).

The capture of spores or bacteria in ELISA depends on the specificity, avidity and the affinity of the antibody that serves as the capturing entity for the intended target. Since antibody–spore complex formation is dependent on the probability of their interaction via diffusion in the well of an ELISA plate, the established method suffers from slower assay time and reduced capture efficiency. In contrast, the more efficient entrapment of microorganisms via a membrane fosters improvements in the detection process by allowing for the direct counting of stained organisms. Furthermore, ELISA, unlike the membrane system imposes experimental constraints that severely limit the ability to efficiently capture, and ultimately monitor the presence of spores and bacteria under continuous fluid flow conditions, such as in the case of the intended application. Likewise, the membrane system offers unique advantages over the ELISA approaches by providing a direct visualization, and characterization of the captured species through epifluorescence imaging. This procedure allows for individual particle counting, and the identification of other species that may potentially be present in the sample through computer algorithms and pattern recognition methods.

3.4. Considerations on dust and contaminants

Postal environments are commonly characterized with abundant varieties and amounts of dust, which are particularly relevant to these studies. The SEM studies (data not shown) have demonstrated that the dust produced through transport, manipulation, and processing of postal mail contains fibers, debris, and various kinds of bacteria. Most significantly, dust contains a large number of particles with a wide size distribution encompassing the size range of a number of biological agents of interest. Furthermore, many of the dust components exhibit autofluorescence, due to the use of fluorescent brighteners and inks in the paper and document industries. Many of the trigger systems currently used in military type detectors repose on size selection principles such as aerodynamic par-

ticle sizing (APS) or flow cytometry (FC), and for the reasons exposed previously, do not appear as the ideal trigger systems (DOT and E, 2001; Fox et al., 2002). Our system was tested in a blind study against triggering by yeast, talc, and powdered detergents. The rate of success was 100% as no false positive was generated. Another major potential problem arising from accumulation of dust in our system is clogging of the filter. We have conducted studies which showed that failure of the flow cell operation occurs only after 60 mg of dust are passed through, building a pressure greater than 60 psi, corresponding to 400 h of postal operation, assuming that the concentration of dust reaching the flow cell is an average $6.2 \mu\text{g/L}$. However, this result is widely dependent on the efficiency of the aerosol system and it is based on the assumption that the aerosol collection system has a built-in capability of discarding at least 95% of dust particles of $10 \mu\text{m}$ or higher. In these conditions, even though the accumulation of dust in the flow cell is inevitable in the long run, the device still exhibits a lifetime well above that desired for military applications (DOT and E, 2001). Additionally, we have shown that it is possible to regenerate the flow cell and extend its lifetime by flushing out up to 99% of the dust, spores, or debris accumulated on the filter. This function was easily implemented through the use of an additional outlet within the top insert of the flow cell, and application of an automated flush protocol sequence

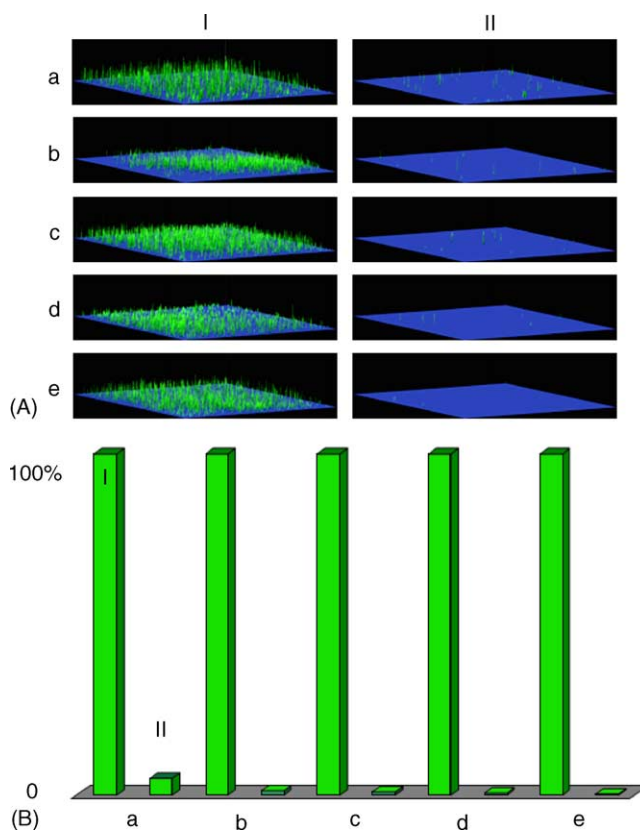

Fig. 5. Illustration of the regeneration capabilities. Surface plot representations of the signal obtained from five consecutive load–unload cycles of the flow cell (A). Bar plot displaying removal efficiency reaching 99% (B).

(Figure S3, Supplementary Materials). A combined method of sonication, backflow, and lateral flow is used to eliminate unwanted material from the membrane without the attention of a technician. This allows for extended operation of the detection system as illustrated by the removal of spore-sized (0.93 μm) fluorescent polymer microspheres from the membrane surface during five consecutive trials in Fig. 5A(a–e). Surface plots in column (i) represents the initial loading of the membrane in the flow cell. The efficiency of the regeneration of the membrane is demonstrated in column (ii). The graph representing the relative percentage of beads remaining on the membrane for each trial is shown in Fig. 5B, where an efficiency of 95, 98, 99, 99, 99% is reached respectively for trials a, b, c, d, and e. Further backflush experiments are underway with spores, and initial results showed similar removal efficiencies with *Bg* spores. Reagents may be circulated in a loop and used again if no agent is discovered. Potential continuous use arising from re-circulation and regeneration capabilities are features consistent with the realization of an inexpensive trigger element.

4. Conclusion

In summary, we have shown that our microchip detection technology can be successfully modified to address important applications of societal relevance. The system was tested with yeast, talc, dust, and succeeded in detecting only a signal due to *B. globigii*, the targeted species used as a simulant for *B. anthracis* in our studies. Our system displays a limit of detection of 500 spores in fewer than 10 min, and has the capability of being fully automated and miniaturized, which makes it very competitive with existing detecting technologies. Its low cost and versatility make it an excellent candidate as a rapid on-line trigger to existing detecting methodologies such as PCR analysis. It can also be customized to detect multiple analytes, therefore enabling rapid microbiology analysis in the field. For example, it can be combined with our bead-based array system, which uses similar fluidic and optical components. In principle, this combination would allow for molecular analysis and bio-particle detection in the same portable reader unit. Species such as *Escherichia coli O157:H7*, *Cryptosporidium*, *Vibrio cholerae*, *Shigella*, *Salmonella*, *Legionella* and *Lysteria* are responsible for world-wide infections and thousands of deaths per year in the US alone, and need to be monitored (Leclerc and Moreau, 2002; Reidl and Klose, 2002; Rose et al., 2002; Steinert et al., 2002; Francis et al., 2001). In addition to the natural or accidental occurrence of most of the diseases caused by bacteria, the impact that intentional contamination of the food and water supplies could have on the general population is tremendous, therefore emphasizing the need for a rapid, cost-effective, and reliable way to detect many of these potentially harmful species. Finally, this system can easily be adapted to the detection of various microbes and living cell enumeration for applications in medical diagnostics.

Acknowledgments

Funding for this project was provided by the National Institute of Health (R01 EB000549-04A1), the U.S. Army Research, Development and Engineering Command, the National Science Foundation, the Beckman Foundation, the Welch Foundation (F-1193), Research Management Group and the Army Research Office (MURI program). Very special thanks are directed to Dr. Thomas O'Brien from Tetra-core Inc. for the generous gift of the anti-*Bacillus globigii* antibody. Finally, Dr. Andrew McFarland and John Mampe are thanked for background information related to postal dust samples.

Appendix A. Supplementary data

Supplementary data associated with this article can be found, in the online version, at doi:10.1016/j.bios.2004.08.046.

References

- Abdel-Hamid, I., Ivnitski, D., Atanasov, P., Wilkins, E., 1999a. Flow-through immunofiltration assay system for rapid detection of *E. coli O157:H7*. *Biosens. Bioelectron.* 14, 309–316.
- Abdel-Hamid, I., Ivnitski, D., Atanasov, P., Wilkins, E., 1999b. Highly sensitive flow-injection immunoassay system for rapid detection of bacteria. *Anal. Chim. Acta* 399, 99–108.
- Belgrader, P., Benett, W., Hadley, D., Richards, J., Stratton, P., Mariella, R., Milanovich, F., 1999. Infectious disease: PCR detection of bacteria in seven minutes. *Science* 284, 449–450.
- Belgrader, P., Elkin, C.J., Brown, S.B., Nasarabadi, S.N., Langlois, R.G., Milanovich, F.P., Colston, B.W., Marshall, G.D., 2003. A reusable flow-through polymerase chain reaction instrument for the continuous monitoring of infectious biological agents. *Anal. Chem.* 75, 3446–3450.
- Belgrader, P., Young, S., Yuan, B., Primeau, M., Christel, L.A., Pourahmadi, F., Northrup, M.A., 2001. A battery-powered notebook thermal cycler for rapid multiplex real-time PCR analysis (73 (2001) 286). *Anal. Chem.* 73, 391.
- Berkson, J., Magath, T.B., Hurn, M., 1939. *Am. J. Physiol.* 128, 309.
- Bockelmann, U., Manz, W., Neu, T.R., Szewzyk, U., 2002. Investigation of lotic microbial aggregates by a combined technique of fluorescent in situ hybridization and lectin-binding-analysis. *J. Microbiol. Methods* 49, 75–87.
- Brewster, J.D., Gehring, A.G., Mazonko, R.S., VanHouten, L.J., Crawford, C.J., 1996. Immunoelectrochemical assays for bacteria: use of epifluorescence microscopy and rapid-scan electrochemical techniques in development of an assay for *Salmonella*. *Anal. Chem.* 68, 4153–4159.
- Brewster, J.D., Mazonko, R.S., 1998. Filtration capture and immunoelectrochemical detection for rapid assay of *Escherichia coli O157:H7*. *J. Immunol. Methods* 211, 1–8.
- Center for Disease Control Atlanta, GA, USA, <http://www.cdc.gov/>.
- Chapman, R.G., Ostuni, E., Liang, M.N., Meluleni, G., Kim, E., Yan, L., Pier, G., Warren, H.S., Whitesides, G.M., 2001. Polymeric thin films that resist the adsorption of proteins and the adhesion of bacteria. *Langmuir* 17, 1225–1233.
- Cheng, Y.S., Barr, E.B., Fan, B.J., Hargis, P.J., Rader, D.J., O'Hern, T.J., Torczynski, J.R., Tisone, G.C., Preppernau, B.L., Young, S.A., Radloff, R.J., 1999. Detection of bioaerosols using multiwave-

- length UV fluorescence spectroscopy. *Aerosol Sci. Technol.* 30, 186–201.
- Cheun, H.I., Makino, S.I., Watarai, M., Shirahata, T., Uchida, I., Takeshi, K., 2001. A simple and sensitive detection system for *Bacillus anthracis* in meat and tissue. *J. Appl. Microbiol.* 91, 421–426.
- Christodoulides, N., Tran, M., Floriano, P.N., Rodriguez, M., Goodey, A., Ali, M., Neikirk, D., McDevitt, J.T., 2002. A microchip-based multianalyte assay system for the assessment of cardiac risk. *Anal. Chem.* 74, 3030–3036.
- Chuang, H., Macuch, P., Tabacco, M.B., 2001. Optical sensors for detection of bacteria. 1. General concepts and initial development. *Anal. Chem.* 73, 462–466.
- Curey, T.E., Goodey, A., Tsao, A., Lavigne, J., Sohn, Y., McDevitt, J.T., Anslyn, E.V., Neikirk, D., Shear, J.B., 2001. Characterization of multicomponent monosaccharide solutions using an enzyme-based sensor array. *Anal. Biochem.* 293, 178–184.
- Davey, H.M., Jones, A., Shaw, A.D., Kell, D.B., 1999. Variable selection and multivariate methods for the identification of microorganisms by flow cytometry. *Cytometry* 35, 162–168.
- Davey, H.M., Kell, D.B., 1997. Fluorescent brighteners: novel stains for the flow cytometric analysis of microorganisms. *Cytometry* 28, 311–315.
- Dill, K., Montgomery, D.D., Wang, W., Tsai, J.C., 2001. Antigen detection using microelectrode array microchips. *Anal. Chim. Acta* 444, 69–78.
- Dill, K., Song, J.H., Blomdahl, J.A., Olson, J.D., 1997. Rapid, sensitive and specific detection of whole cells and spores using the light-addressable potentiometric sensor. *J. Biochem. Biophys. Methods* 34, 161–166.
- DOT and E, Director of Operational Test and Evaluation Activity Summary and Program Oversight, 2001. Joint Biological Point Detection System (JBPDs) FY01 Annual Report, <http://www.globalsecurity.org/military/library/budget/fy2001/dote/other/01jbpd.html>.
- Dull, P.M., Wilson, K.E., Kournikakis, B., Whitney, E.A.S., Boulet, C.A., Ho, J.Y.W., Ogston, J., Spence, M.R., McKenzie, M.M., Phelan, M.A., Popovic, T., Ashford, D., 2002. *Bacillus anthracis* aerosolization associated with a contaminated mail sorting machine. *Emerg. Infect. Dis.* 8, 1044–1047.
- Fox, A., Anderson, M., Dunn, J., Guenther, B., Parks, L., Pinnick, R., Reed, C., Rowe, J., Luftig, R., Long, G.W., Lontz, R., Marchin, G.L., McManus, A.T., Setlow, P., Siedow, J., Sievers, A.J., Tchikindas, M.L., Tove, S., 2002. Report of the “Bioterrorism Workshop”—Duke University Thomas Center on 2–4 April 2002 organized by US Army Research Office. *J. Microbiol. Methods* 51, 247–254.
- Francis, C.A., Lockley, A.C., Sartory, D.P., Watkins, J., 2001. A simple modified membrane filtration medium for the enumeration of aerobic spore-bearing bacilli in water. *Water Res.* 35, 3758–3761.
- Gau, J.J., Lan, E.H., Dunn, B., Ho, C.M., Woo, J.C.S., 2001. A MEMS based amperometric detector for *E. coli* bacteria using self-assembled monolayers. *Biosens. Bioelectron.* 16, 745–755.
- Goodey, A., Lavigne, J.J., Savoy, S.M., Rodriguez, M.D., Curey, T., Tsao, A., Simmons, G., Wright, J., Yoo, S.J., Sohn, Y., Anslyn, E.V., Shear, J.B., Neikirk, D.P., McDevitt, J.T., 2001. Development of multianalyte sensor arrays composed of chemically derivatized polymeric microspheres localized in micromachined cavities. *J. Am. Chem. Soc.* 123, 2559–2570.
- Iqbal, S.S., Mayo, M.W., Bruno, J.G., Bronk, B.V., Batt, C.A., Chambers, J.P., 2000. A review of molecular recognition technologies for detection of biological threat agents. *Biosens. Bioelectron.* 15, 549–578.
- Ivniński, D., Abdel-Hamid, I., Atanasov, P., Wilkins, E., 1999. Biosensors for detection of pathogenic bacteria. *Biosens. Bioelectron.* 14, 599–624.
- Kaprelyants, A.S., Kell, D.B., 1992. Rapid assessment of bacterial viability and vitality by Rhodamine 123 and flow-cytometry. *J. Appl. Bacteriol.* 72, 410–422.
- King, K.D., Vanniere, J.M., Leblanc, J.L., Bullock, K.E., Anderson, G.P., 2000. Automated fiber optic biosensor for multiplexed immunoassays. *Environ. Sci. Technol.* 34, 2845–2850.
- Lavigne, J.J., Savoy, S., Clevenger, M.B., Ritchie, J.E., McDoniel, B., Yoo, S.J., Anslyn, E.V., McDevitt, J.T., Shear, J.B., Neikirk, D., 1998. Solution-based analysis of multiple analytes by a sensor array: toward the development of an “electronic tongue”. *J. Am. Chem. Soc.* 120, 6429–6430.
- Leclerc, H., Moreau, A., 2002. Microbiological safety of natural mineral water. *FEMS Microbiol. Rev.* 26, 207–222.
- Lee, W., Saito, K., Furusaki, S., Sugo, T., 1997. Capture of microbial cells on brush-type polymeric materials bearing different functional groups. *Biotechnol. Bioeng.* 53, 523–528.
- Liu, W.T., Mirzabekov, A.D., Stahl, D.A., 2001. Optimization of an oligonucleotide microchip for microbial identification studies: a non-equilibrium dissociation approach. *Environ. Microbiol.* 3, 619–629.
- MacGregor, B.J., Toze, S., Alm, E.W., Sharp, R., Ziemer, C.J., Stahl, D.A., 2001. Distribution and abundance of Gram-positive bacteria in the environment: development of a group-specific probe. *J. Microbiol. Methods* 44, 193–203.
- Makino, S.I., Cheun, H.I., Watarai, M., Uchida, I., Takeshi, K., 2001. Detection of anthrax spores from the air by real-time PCR. *Lett. Appl. Microbiol.* 33, 237–240.
- Mason, D.J., Lopezamoros, R., Allman, R., Stark, J.M., Lloyd, D., 1995. The ability of membrane-potential dyes and calcafluor white to distinguish between viable and nonviable bacteria. *J. Appl. Bacteriol.* 78, 309–315.
- Mazenko, R.S., Rieders, F., Brewster, J.D., 1999. Filtration capture immunoassay for bacteria: optimization and potential for urinalysis. *J. Microbiol. Methods* 36, 157–165.
- McBride, M.T., Masquelier, D., Hindson, B.J., Makarewicz, A.J., Brown, S., Burris, K., Metz, T., Langlois, R.G., Tsang, K.W., Bryan, R., Anderson, D.A., Venkateswaran, K.S., Milanovich, F.P., Colston, B.W., 2003. Autonomous detection of aerosolized *Bacillus anthracis* and *Yersinia pestis*. *Anal. Chem.* 75, 5293–5299.
- Morais, S., GonzalezMartinez, M.A., Abad, A., Montoya, A., Maquieira, A., Puchades, R., 1997. A comparative study by the enzyme-linked immunofiltration assay of solid phases used in the development of flow immunosensors. *J. Immunol. Methods* 208, 75–83.
- NATIBO, North American Technology and Industrial Base Organization, 2001. Biological Detection System Technologies. Technology and industrial base study. A primer on biological detection technologies, TRW systems and information technology group, <http://www.dtic.mil/natibo/docs/BioDetectReport-2.pdf>.
- Paton, A.M., Jones, S.M., 1975. Observation and enumeration of microorganisms in fluids using membrane filtration and incident fluorescence microscopy. *J. Appl. Bacteriol.* 38, 199–200.
- Phillips, A.P., Martin, K.L., Broster, M.G., 1983. Differentiation between spores of *Bacillus anthracis* and *Bacillus cereus* by a quantitative immunofluorescence technique. *J. Clin. Microbiol.* 17, 41–47.
- Phillips, M.K., Roberts, M.E.R., Kell, D.B., 1985. Tinopal as a selective agent for the differentiation of phytopathogenic and saprophytic pseudomonas species. *J. Appl. Bacteriol.* 58, 283–292.
- Radosevich, J.L., Wilson, W.J., Shinn, J.H., DeSantis, T.Z., Andersen, G.L., 2002. Development of a high-volume aerosol collection system for the identification of air-borne micro-organisms. *Lett. Appl. Microbiol.* 34, 162–167.
- Reidl, J., Klose, K.E., 2002. *Vibrio cholerae* and cholera: out of the water and into the host. *FEMS Microbiol. Rev.* 26, 125–139.
- Rose, J.B., Huffman, D.E., Gennaccaro, A., 2002. Risk and control of waterborne cryptosporidiosis. *FEMS Microbiol. Rev.* 26, 113–123.
- Rowe, C.A., Tender, L.M., Feldstein, M.J., Golden, J.P., Scruggs, S.B., MacCraith, B.D., Cras, J.J., Ligler, F.S., 1999. Array biosensor for simultaneous identification of bacterial, viral, and protein analytes. *Anal. Chem.* 71, 3846–3852.
- Shintani, T., Yamada, K., Torimura, M., 2002. Optimization of a rapid and sensitive identification system for *Salmonella enteritidis* by capillary

- electrophoresis with laser-induced fluorescence. *FEMS Microbiol. Lett.* 210, 245–249.
- Song, J., Cheng, Q., Zhu, S.M., Stevens, R.C., 2002. “Smart” materials for biosensing devices: cell-mimicking supramolecular assemblies and colorimetric detection of pathogenic agents. *Biomed. Microdevices* 4, 213–221.
- Speight, S.E., Hallis, B.A., Bennett, A.M., Benbough, J.E., 1997. Enzyme-linked immunosorbent assay for the detection of airborne microorganisms used in biotechnology. *J. Aerosol Sci.* 28, 483–492.
- Steinert, M., Hentschel, U., Hacker, J., 2002. *Legionella pneumophila*: an aquatic microbe goes astray. *FEMS Microbiol. Rev.* 26, 149–162.
- Szczesna-Antczak, M., Galas, E., 2001. *Bacillus subtilis* cells immobilised in PVA-cryogels. *Biomol. Eng.* 17, 55–63.
- Weimer, B.C., Walsh, M.K., Beer, C., Koka, R., Wang, X., 2001. Solid-phase capture of proteins, spores, and bacteria. *Appl. Environ. Microbiol.* 67, 1300–1307.
- Wilson, W.J., Strout, C.L., DeSantis, T.Z., Stilwell, J.L., Carrano, A.V., Andersen, G.L., 2002. Sequence-specific identification of 18 pathogenic microorganisms using microarray technology. *Mol. Cell. Probes* 16, 119–127.
- Wu, Z.H., Blomquist, G., Westermark, S.O., Wang, X.T., 2002. Application of PCR and probe hybridization techniques in detection of airborne fungal spores in environmental samples. *J. Environ. Monit.* 4, 673–678.
- Yang, J.M., Bell, J., Huang, Y., Tirado, M., Thomas, D., Forster, A.H., Haigis, R.W., Swanson, P.D., Wallace, R.B., Martinsons, B., Krihak, M., 2002. An integrated, stacked microlaboratory for biological agent detection with DNA and immunoassays. *Biosens. Bioelectron.* 17, 605–618.
- Yu, H., 1996. Enhancing immunoelectrochemiluminescence (IECL) for sensitive bacterial detection. *J. Immunol. Methods* 192, 63–71.
- Yu, H., 1998. Comparative studies of magnetic particle-based solid phase fluorogenic and electrochemiluminescent immunoassay. *J. Immunol. Methods* 218, 1–8.